

ISP1040B Intelligent SCSI Processor

Data Sheet

Features

- Compliance with ANSI SCSI standard X3.131-1994
- Compliance with ANSI SCSI configured automatically (SCAM) protocol levels 1 and 2
- Compliance with ANSI X3T10/855D SCSI-3 parallel interface (SPI) standard
- Compliance with ANSI X3T10/1071D Fast-20 standard
- Onboard RISC processor to execute operations at the I/O control block level from the host memory
- Supports fast, wide, and Ultra (Fast-20) SCSI data transfer rates
- SCSI initiator and target modes of operation
- 32-bit, intelligent bus master, DMA PCI bus interface

- SCSI operations executed from start to finish without host intervention
- Simultaneous, multiple logical threads
- JTAG boundary scan support

Product Description

The ISP1040B is a single-chip, highly integrated, bus master, SCSI I/O processor for use in SCSI initiator-type applications. The device interfaces the PCI bus to a wide, Ultra SCSI bus and contains an onboard RISC processor. The ISP1040B is a fully autonomous device, capable of managing multiple I/O operations and associated data transfers from initiation to completion without host CPU intervention. The ISP1040B block diagram is illustrated in figure 1.

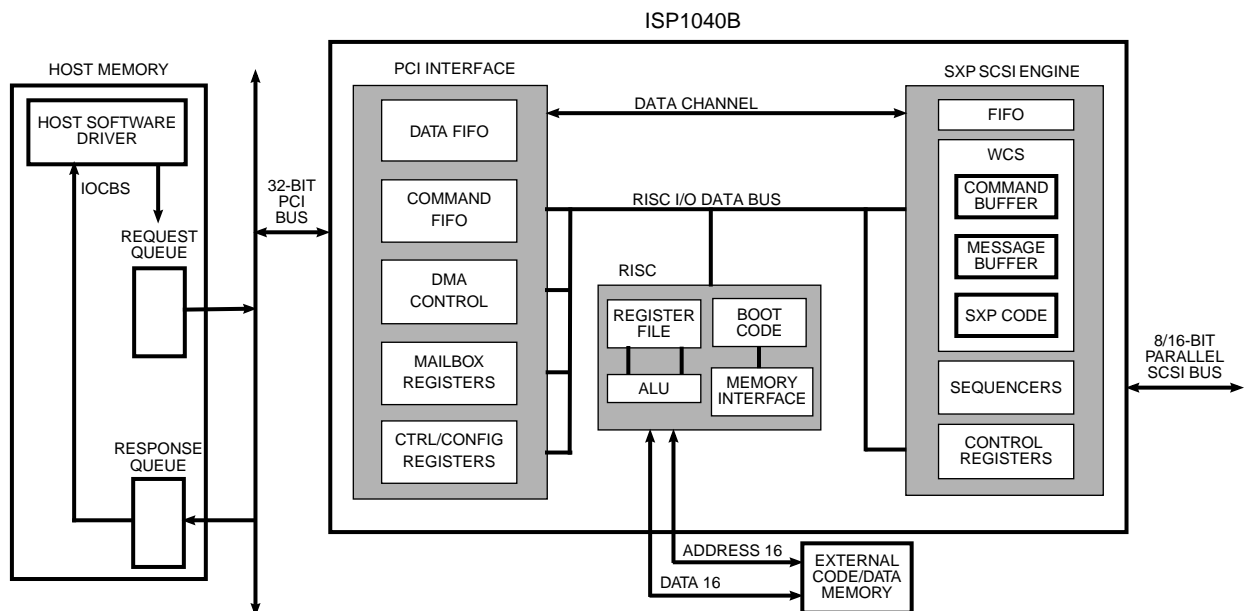

Figure 1. ISP1040B Block Diagram

ISP Initiator and Target Firmware

The ISP1040B firmware implements a cooperative, multitasking host adapter that provides the host system with complete SCSI command and data transport capabilities, thus freeing the host system from the demands of the SCSI bus protocol. The ISP1040B firmware provides two interfaces to the host system: the command interface and the SCSI transport interface. The single-threaded command interface facilitates debugging, configuration, and error recovery. The multithreaded SCSI transport interface maximizes use of the SCSI and host buses. The ISP1040B can switch between initiator and target modes.

I/O Subsystem Organization

To maximize I/O throughput and improve host and SCSI bus utilization, the ISP1040B incorporates a high-speed, proprietary RISC processor; an intelligent SCSI bus controller (SCSI executive processor [XSP]); and a host bus, dual-channel DMA controller. The SCSI bus controller and the host bus DMA controller operate independently and concurrently under control of the onboard RISC processor for maximum system performance. The ISP1040B RISC interface requires external program data memory.

The complete I/O subsystem solution using the ISP1040B and associated supporting memory devices is shown in figure 2.

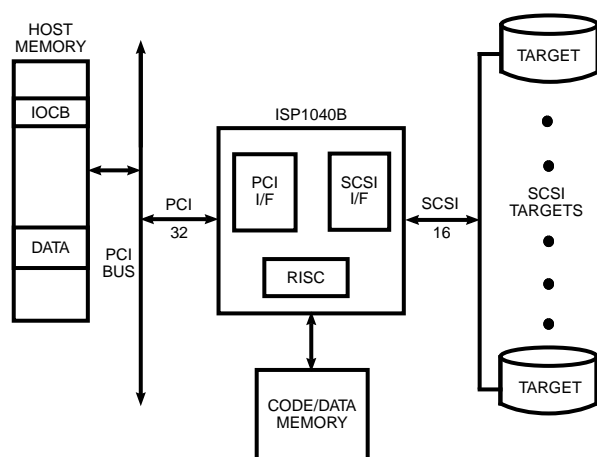

Figure 2. I/O Subsystem Design Using the ISP1040B

Interfaces

The ISP1040B supports the following interfaces:

- PCI bus
- RISC processor
- SCSI executive processor

Pins that support these interfaces and other chip operations are shown in figure 3.

PCI Bus Interface

The ISP1040B PCI bus interface supports the following:

- 128-byte data DMA FIFO and 64-byte command DMA FIFO with threshold control
- 16-bit target mode
- DMA FIFO management, data alignment, data assembly, and data disassembly
- *PCI Local Bus Specification* revision 2.1 compliant
- Support for subsystem ID and subsystem vendor ID
- Dual voltage (3.3V and 5.0V) PCI I/O buffers
- Flash ROM support

The ISP1040B is designed to interface directly to the PCI local bus and operate as a 32-bit DMA master. This function is accomplished through the PCI bus interface unit (PBIU) containing an onboard DMA controller. The PBIU generates and samples PCI bus control signals, generates host memory addresses, and facilitates data transfers between host memory and the onboard DMA FIFO. The PBIU also allows the host to access the ISP1040B internal registers and communicate with the onboard RISC processor through the PCI bus target mode operation.

The ISP1040B onboard DMA controller consists of two independent DMA channels that initiate transactions on the PCI bus and transfer data between the memory and DMA FIFO. The two DMA channels are the command DMA channel and the data DMA channel. The command DMA channel is used mainly by the RISC processor for small transfers such as fetching commands from and writing status information to the host memory over the PCI bus. The data DMA channel transfers data between the SCSI bus and the PCI bus.

The PBIU internally arbitrates between the data DMA channel and the command DMA channel and alternately services them. Each DMA channel has a set of DMA registers that are programmed for transfers by the RISC processor.

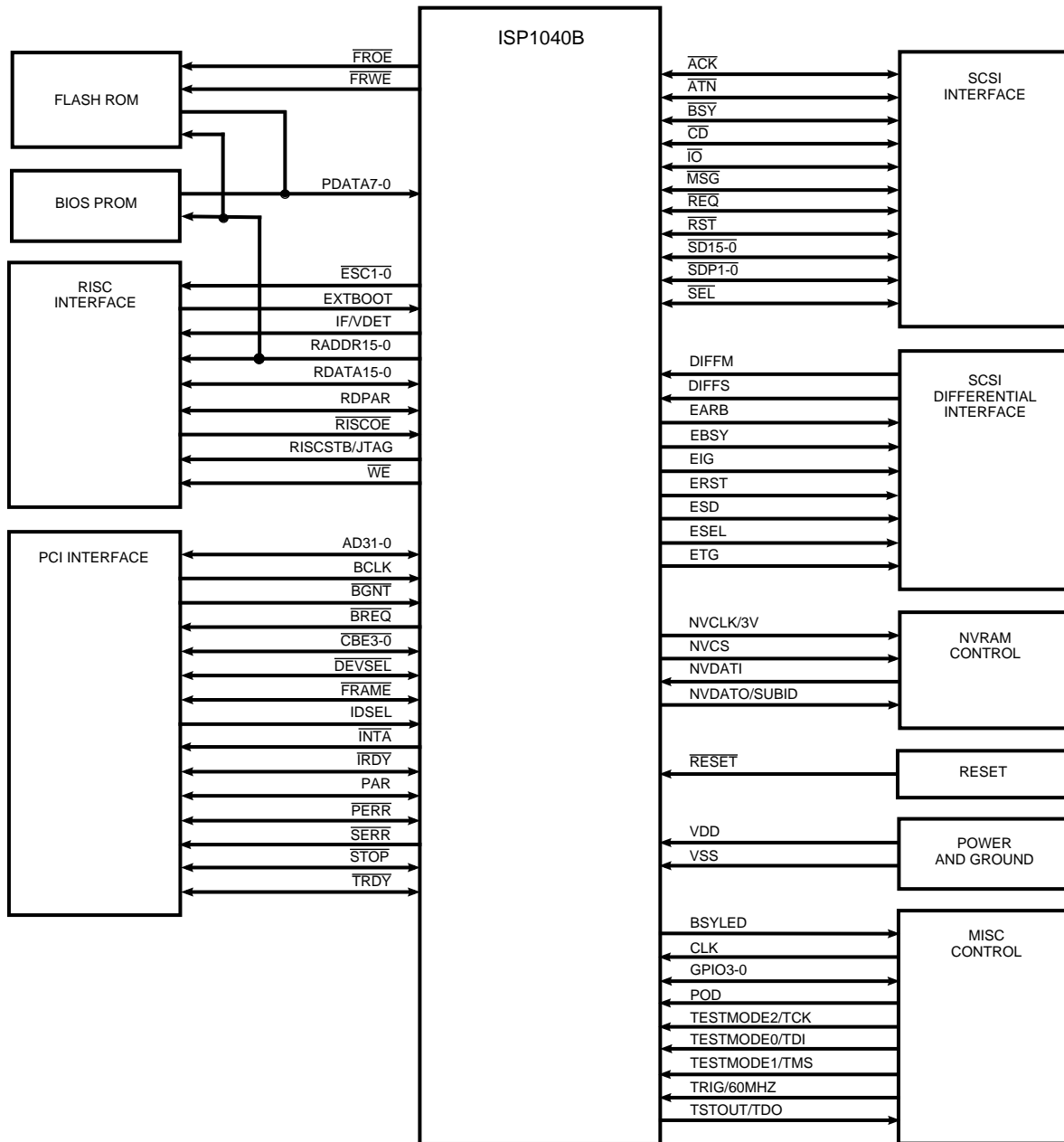

Figure 3. ISP1040B Functional Signal Grouping

RISC Processor Interface

The ISP1040B RISC processor interface supports the following:

- Programmable cycle time for external memory access
- Internal 16-bit wide data paths
- Execution of multiple I/O control blocks from the host memory
- Management of onboard host bus DMA controller and SCSI bus controller
- Reduced host intervention and interrupt overhead
- Capacity to generate one interrupt per I/O operation

The onboard RISC processor enables the ISP1040B to handle complete I/O transactions with no intervention from the host. The ISP1040B RISC processor controls the chip

interfaces; executes simultaneous, multiple input/output control blocks (IOCBs); and maintains the required thread information for each transfer.

SCSI Executive Processor Interface

The ISP1040B SXP interface supports the following:

- SCAM level 1 and level 2 support
 - 32-byte FIFO with parity pass-through option
 - Command, status, message in, and message out buffers
 - Device information storage area
- SCSI synchronous transfer rates of 40 Mbytes/sec (requires 60-MHz clock)
- SCSI asynchronous transfer rate of 12 Mbytes/sec

- Programmable SCSI processor
 - Specialized instruction set with 16-bit microword
 - 384-bit by 16-bit internal control store RAM
- Diagnostic support

The SXP provides an autonomous, intelligent SCSI interface capable of handling complete SCSI operations. The SXP interrupts the RISC processor only to handle higher level functions such as threaded operations or error handling.

Packaging

The ISP1040B is available in a 208-pin plastic quad flat pack (PQFP). Package dimensions are shown in figure 4.

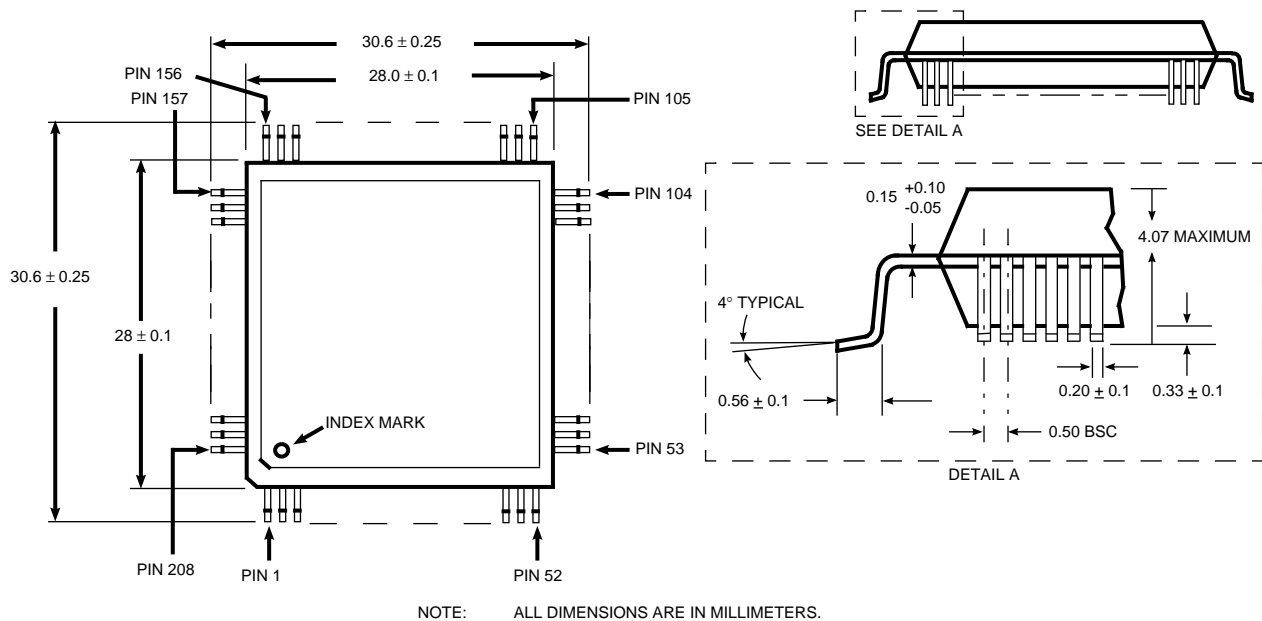

Figure 4. ISP1040B Mechanical Drawings

Specifications are subject to change without notice.
QLogic is a trademark of QLogic Corporation.

